

VERSIONS

Mounting flange	Shaft	Port size	European version	US version	Side port version	End port version	Flange port version	Standard shaft seal	High pressure shaft seal	Drain connection	Check valve	Specials	Main type designation
2 hole oval flange (A2-flange)	Cyl. 25 mm	G 1/2	X		X				X	No	No		OMR
		G 1/2	X		X				X	Yes	Yes		OMR
		G 1/2	X		X			X		Yes	Yes	A	OMR C
		G 1/2	X			X		X		Yes	Yes		OMR
	Cyl 1 in	G 1/2	X		X				X	No	No		OMR
		G 1/2	X		X				X	Yes	Yes		OMR
		7/8 - 14 UNF		X	X			X		Yes	Yes		OMR
	Splined 1 in	G 1/2	X		X				X	No	No		OMR
		G 1/2	X		X				X	Yes	Yes		OMR
		7/8 - 14 UNF		X	X			X		Yes	Yes		OMR
Cyl. 32 mm	G 1/2	X		X			X		Yes	Yes		OMR	
Tap. 28.5 mm	G 1/2	X		X			X		Yes	Yes		OMR	
4 hole oval flange (A4-flange)	Cyl. 25 mm	G 1/2	X		X			X		Yes	Yes		OMR
	Cyl. 32 mm	G 1/2	X		X			X		Yes	Yes		OMR
	Cyl. 1 1/4 in	7/8 - 14 UNF		X	X			X		Yes	Yes		OMR
Square flange (C-flange)	Cyl. 25 mm	G 1/2	X			X		X		Yes	Yes		OMR
	Cyl. 1 in	7/8 - 14 UNF		X	X			X		Yes	Yes		OMR
Wheel	Tap. 35 mm	G 1/2	X				X	X		Yes	Yes	B	OMRW N
	Tap. 1 1/4 in	7/8 - 14 UNF		X			X	X		Yes	Yes	B	OMRW N

Function diagram – see page : →

Specials:

A : Corrosion resistant parts
B : With needle bearings

Features available (options) :

Free running gerotor
Low leakage (low speed valve)
Speed sensor
Viton shaft seal
Reverse rotation
Drain
Corrosion protected
Painted
With needle bearings
With brake

CODE NUMBERS

CODE NUMBERS	DISPLACEMENT [cm ³]									Technical data – Page	Dimensions – Page
	50	80	100	125	160	200	250	315	375		
151-	0410	0411	0412	0413	0414	0415	0416	0417	0418	38	55
151-	0710	0711	0712	0713	0714	0715	0716	0717	0718	38	56
151-	1231	1232	1233	1238	1234	1235	1236	1237	1243	38	57
151-	6190	6191	6192	6193	6194	6195	6196	6197	6198	38	58
151-	0400	0401	0402	0403	0404	0405	0406	0407	0408	38	55
151-	0700	0701	0702	0703	0704	0705	0706	0707	0708	38	56
151-	7240	7241	7242	7243	7244	7245	7246	7247	7248	38	59
151-	0420	0421	0422	0423	0424	0425	0426	0427	0428	39	55
151-	0720	0721	0722	0723	0724	0725	0726	0727	0728	39	56
151-	7250	7251	7252	7253	7254	7255	7256	7257	7258	39	59
151-	0248	0242	0243	0208	0244	0245	0247	0246	6294	40	57
151-	0265	0266	0267	6295	0268	0269	0271	0270	6296	39	57
151-	6010	6011	6012	6013	6014	6015	6016	6017	6018	38	60
151-	6000	6001	6002	6003	6004	6005	6006	6007	6008	40	60
151-	6110	6111	6112	6113	6114	6115	6116	6117	6118	40	61
151-	6210	6211	6212	6213	6214	6215	6216	6217	6218	38	62
151-	7260	7261	7262	7263	7264	7265	7266	7267	7269	38	63
151-	6300	6301	6302	6303	6304	6305	6306	6307	6308	40	64
151-	6430	6431	6432	6433	6434	6435	6436	6437	6438	40	650
	45	45	46	46	47	47	48	48	49		

Ordering

Add the four digit prefix "151-" to the four digit numbers from the chart for complete code number.

Example:

151-6004 for an OMR 160 with A4 flange, cyl. 32 mm shaft, port size G 1/2 and side port version.

Note: Orders will not be accepted without the four digit prefix.

TECHNICAL DATA FOR OMR WITH 25 MM AND 1 IN CYLINDRICAL SHAFT

Type		OMR	OMR	OMR	OMR	OMR	OMR	OMR	OMR	OMR	
Motor size		50	80	100	125	160	200	250	315	375	
Geometric displacement	cm ³ (in ³)	51.6 (3.16)	80.3 (4.91)	99.8 (6.11)	125.7 (7.69)	159.6 (9.77)	199.8 (12.23)	249.3 (15.26)	315.7 (19.32)	372.6 (22.80)	
Max. speed	min ⁻¹ (rpm)	cont.	775	750	600	475	375	300	240	190	160
		int. ¹⁾	970	940	750	600	470	375	300	240	200
Max. torque	Nm (lbf-in)	cont.	100 (890)	195 (1730)	240 (2120)	300 (2660)	300 (2660)	300 (2660)	300 (2660)	300 (2660)	300 (2660)
		int. ¹⁾	130 (1150)	220 (1957)	280 (2480)	340 (3010)	390 (3450)	390 (3450)	380 (3360)	420 (3720)	430 (3810)
		peak ²⁾	170 (1510)	270 (2390)	320 (2830)	370 (3280)	460 (4070)	560 (4960)	600 (5310)	610 (5400)	600 (5310)
Max. output	kW (hp)	cont.	7.0 (9.4)	12.5 (16.8)	13.0 (17.4)	12.5 (16.8)	10.0 (13.4)	8.0 (10.7)	6.0 (8.1)	5.0 (6.7)	4.0 (5.4)
		int. ¹⁾	8.5 (11.4)	15.0 (20.1)	15.0 (20.1)	14.5 (19.4)	12.5 (16.8)	10.0 (13.4)	8.0 (10.7)	6.5 (8.7)	6.0 (8.1)
Max. pressure drop	bar (psi)	cont.	140 (2030)	175 (2540)	175 (2540)	175 (2540)	130 (1890)	110 (1600)	80 (1160)	70 (1020)	55 (800)
		int. ¹⁾	175 (2540)	200 (2900)	200 (2900)	200 (2900)	175 (2540)	140 (2030)	110 (1600)	100 (1450)	85 (1230)
		peak ²⁾	225 (3260)	225 (3260)	225 (3260)	225 (3260)	225 (3260)	225 (3260)	200 (2900)	150 (2180)	130 (1890)
Max. oil flow	l/min (US gal/min)	cont.	40 (10.6)	60 (15.9)	60 (15.9)	60 (15.9)	60 (15.9)	60 (15.9)	60 (15.9)	60 (15.9)	60 (15.9)
		int. ¹⁾	50 (13.2)	75 (19.8)	75 (19.8)	75 (19.8)	75 (19.8)	75 (19.8)	75 (19.8)	75 (19.8)	75 (19.8)
Max. starting pressure with unloaded shaft	bar (psi)	10 (145)	10 (145)	10 (145)	9 (130)	7 (100)	5 (75)	5 (75)	5 (75)	5 (75)	
Min. starting torque	at max. press. drop cont.	80 (710)	150 (1330)	200 (1770)	250 (2210)	240 (2120)	260 (2300)	240 (2120)	260 (2300)	240 (2120)	
	at max. press. drop int. ¹⁾	100 (890)	170 (1500)	230 (2040)	280 (2480)	320 (2830)	330 (2920)	310 (2740)	350 (3100)	380 (3360)	
Min. speed ³⁾	min ⁻¹ (rpm)	10	10	10	9	7	5	5	5	5	

¹⁾ Intermittent operation: the permissible values may occur for max. 10% of every minute.

²⁾ Peak load: the permissible values may occur for max. 1% of every minute.

³⁾ Operation at lower speeds may be slightly less smooth.

TECHNICAL DATA FOR OMR WITH 1 IN SPLINED AND 28.5 MM TAPERED SHAFT

Type		OMR	OMR	OMR	OMR	OMR	OMR	OMR	OMR	OMR	
Motor size		50	80	100	125	160	200	250	315	375	
Geometric displacement	cm ³ (in ³)	51.6 (3.16)	80.3 (4.91)	99.8 (6.11)	125.7 (7.69)	159.6 (9.77)	199.8 (12.23)	249.3 (15.26)	315.7 (19.32)	372.6 (22.80)	
Max. speed	min ⁻¹ (rpm)	cont.	775	750	600	475	375	300	240	190	160
		int. ¹⁾	970	940	750	600	470	375	300	240	200
Max. torque	Nm (lbf-in)	cont.	100 (890)	195 (1730)	240 (2120)	300 (2660)	360 (3190)	360 (3190)	360 (3190)	360 (3190)	360 (3190)
		int. ¹⁾	130 (1150)	220 (1950)	280 (2480)	340 (3010)	430 (3810)	440 (3890)	470 (4160)	470 (4160)	460 (4070)
		peak ²⁾	170 (1500)	270 (2390)	320 (2830)	370 (3280)	460 (4070)	560 (4960)	600 (5310)	610 (5400)	600 (5310)
Max. output	kW (hp)	cont.	7.0 (9.4)	12.5 (16.8)	13.0 (17.4)	12.5 (16.8)	12.5 (16.8)	10.0 (13.4)	7.0 (9.4)	5.0 (6.7)	5.0 (6.7)
		int. ¹⁾	8.5 (11.4)	15.0 (20.1)	15.0 (20.1)	14.5 (19.4)	14.0 (18.8)	13.0 (17.4)	9.5 (12.7)	8.0 (10.7)	7.0 (9.4)
Max. pressure drop	bar (psi)	cont.	140 (2030)	175 (2540)	175 (2540)	175 (2540)	165 (2390)	130 (1890)	100 (1450)	85 (1230)	70 (1020)
		int. ¹⁾	175 (2540)	200 (2900)	200 (2900)	200 (2900)	200 (2900)	175 (2540)	140 (2030)	115 (1670)	90 (1310)
		peak ²⁾	225 (3260)	225 (3260)	225 (3260)	225 (3260)	225 (3260)	225 (3260)	200 (2900)	150 (2180)	130 (1890)
Max. oil flow	l/min (US gal/min)	cont.	40 (10.6)	60 (15.9)	60 (15.9)	60 (15.9)	60 (15.9)	60 (15.9)	60 (15.9)	60 (15.9)	60 (15.9)
		int. ¹⁾	50 (13.2)	75 (19.8)	75 (19.8)	75 (19.8)	75 (19.8)	75 (19.8)	75 (19.8)	75 (19.8)	75 (19.8)
Max. starting pressure with unloaded shaft	bar (psi)	10 (145)	10 (145)	10 (145)	9 (131)	7 (102)	5 (73)	7 (102)	5 (73)	5 (73)	
Min. starting torque	at max. press. drop cont.	80 (710)	150 (1330)	200 (1770)	250 (2210)	300 (2660)	300 (2660)	290 (2570)	315 (2790)	300 (2660)	
	at max. press. drop int. ¹⁾	100 (890)	170 (1500)	230 (2040)	280 (2480)	350 (3100)	400 (3540)	400 (3540)	400 (3540)	380 (3360)	
Min. speed ³⁾	min ⁻¹ (rpm)	10	10	10	9	7	5	5	5	5	

¹⁾ Intermittent operation: the permissible values may occur for max. 10% of every minute.

²⁾ Peak load: the permissible values may occur for max. 1% of every minute.

³⁾ Operation at lower speeds may be slightly less smooth.

TECHNICAL DATA FOR OMR/OMRW WITH 32 MM, 1 1/4 IN CYLINDRICAL SHAFT AND 35 MM, 1 1/4 IN TAPERED SHAFT

Type		OMR	OMR	OMR	OMR	OMR	OMR	OMR	OMR	OMR	
Motor size		50	80	100	125	160	200	250	315	375	
Geometric displacement	cm ³ (in ³)	51.6 (3.16)	80.3 (4.91)	99.8 (6.11)	125.7 (7.69)	159.6 (9.77)	199.8 (12.23)	249.3 (15.26)	315.7 (19.32)	372.6 (22.80)	
Max. Speed	min ⁻¹ (rpm)	cont.	775	750	600	475	375	300	240	190	160
		int. ¹⁾	970	940	750	600	470	375	300	240	200
Max. Torque	Nm (lbf-in)	cont.	100 (890)	195 (1730)	240 (2120)	300 (2660)	380 (3360)	450 (3980)	540 (4780)	550 (4870)	580 (5130)
		int. ¹⁾	130 (1150)	220 (1950)	280 (2480)	340 (3010)	430 (3810)	500 (4430)	610 (5400)	690 (6110)	690 (6110)
		peak ²⁾	170 (1510)	270 (2390)	320 (2830)	370 (3280)	460 (4070)	560 (4960)	710 (6280)	840 (7440)	830 (7350)
Max. output	kW (hp)	cont.	7.0 (9.4)	12.5 (16.8)	13.0 (17.4)	12.5 (16.8)	12.5 (16.8)	11.0 (14.8)	10.0 (13.4)	9.0 (12.1)	7.5 (10.1)
		int. ¹⁾	8.5 (11.4)	15.0 (20.1)	15.0 (20.1)	14.5 (19.4)	14.0 (18.8)	13.0 (17.4)	12.0 (16.1)	10.0 (13.4)	9.0 (12.1)
Max. pressure drop	bar (psi)	cont.	140 (2030)	175 (2540)	175 (2540)	175 (2540)	175 (2540)	175 (2540)	175 (2540)	135 (1960)	115 (1670)
		int. ¹⁾	175 (2540)	200 (2900)	200 (2900)	200 (2900)	200 (2900)	200 (2900)	200 (2900)	175 (2540)	150 (2180)
		peak ²⁾	225 (3260)	225 (3260)	225 (3260)	225 (3260)	225 (3260)	225 (3260)	225 (3260)	225 (3260)	210 (3050)
Max. oil flow	l/min (USgal/min)	cont.	40 (10.6)	60 (15.9)	60 (15.9)	60 (15.9)	60 (15.9)	60 (15.9)	60 (15.9)	60 (15.9)	60 (15.9)
		int. ¹⁾	50 (13.2)	75 (19.8)	75 (19.8)	75 (19.8)	75 (19.8)	75 (19.8)	75 (19.8)	75 (19.8)	75 (19.8)
Max. starting pressure with unloaded shaft	bar (psi)	10 (145)	10 (145)	10 (145)	9 (130)	7 (100)	5 (75)	5 (75)	5 (75)	5 (75)	
Min. starting torque	at max. press. drop cont.	80 (710)	150 (1330)	200 (1770)	250 (2210)	320 (2830)	410 (3630)	500 (4430)	500 (4430)	470 (4170)	
	at max. press. drop int. ¹⁾	100 (890)	170 (1500)	230 (2040)	280 (2480)	370 (3280)	460 (4070)	550 (4870)	660 (5840)	570 (5050)	
Min. speed ³⁾	min ⁻¹ (rpm)	10	10	10	9	7	5	5	5	5	

Type		Max. inlet pressure	Max. return pressure with drain line
OMR 50 - 375	bar (psi) cont.	175 (2540)	175 (2540)
	bar (psi) int. ¹⁾	200 (2900)	200 (2900)
	bar (psi) peak ²⁾	225 (3260)	225 (3260)

¹⁾ Intermittent operation: the permissible values may occur for max. 10% of every minute.

²⁾ Peak load: the permissible values may occur for max. 1% of every minute.

³⁾ Operation at lower speeds may be slightly less smooth.

OMR WITH HIGH PRESSURE SHAFT SEAL (HPS)

OMR with HPS, without check valves and without drain connection:

The shaft seal pressure equals the average of input pressure and return pressure

$$P_{\text{seal}} = \frac{P_{\text{in}} + P_{\text{return}}}{2}$$

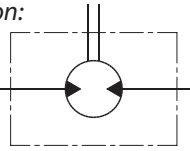

151-1743.10

OMR with HPS, check valves and with drain connection:

The shaft seal pressure equals the pressure in the drain line.

OMR with HPS, check valves and without drain connection:

The pressure on the shaft seal never exceeds the pressure in the return line.

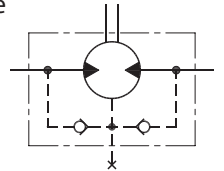

151-320.10

Max. permissible shaft seal pressure

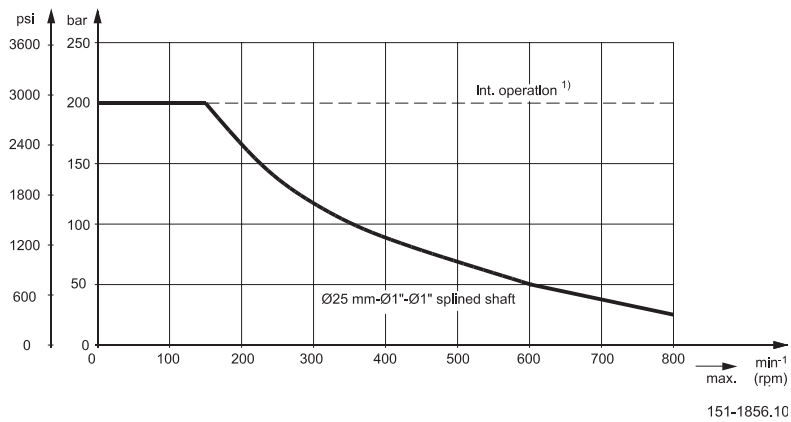

151-1856.10

OMR WITH STANDARD SHAFT SEAL

OMR with standard shaft seal, check valves and without use of drain connection:

The pressure on the shaft seal never exceeds the pressure in the return line

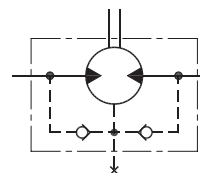

151-320.10

OMR with standard shaft seal, check valves and with drain connection:

The shaft seal pressure equals the pressure on the drain line.

Max. return pressure without drain line or max. pressure in the drain line

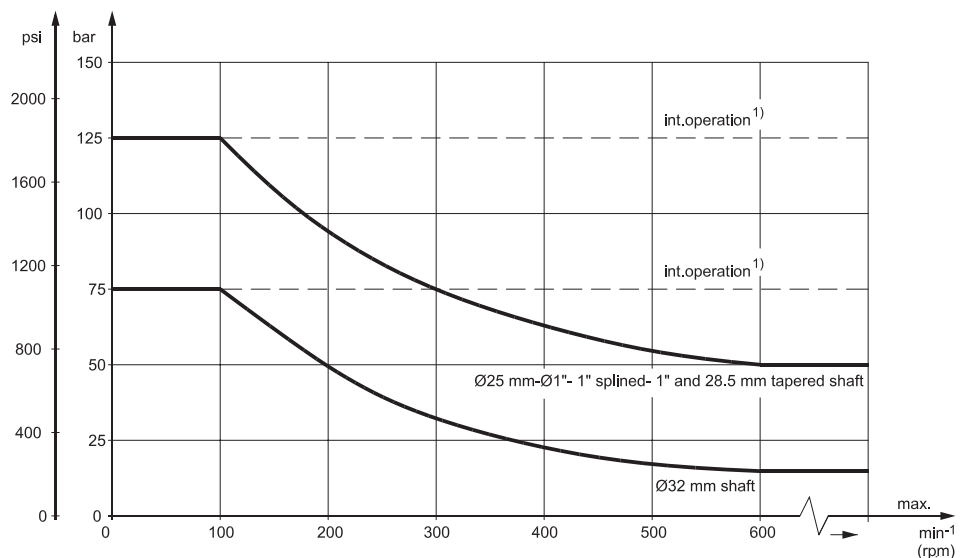

¹⁾ Intermittent operation: the permissible values may occur for max. 10% of every minute.

151-1563.10

PRESSURE DROP IN MOTOR

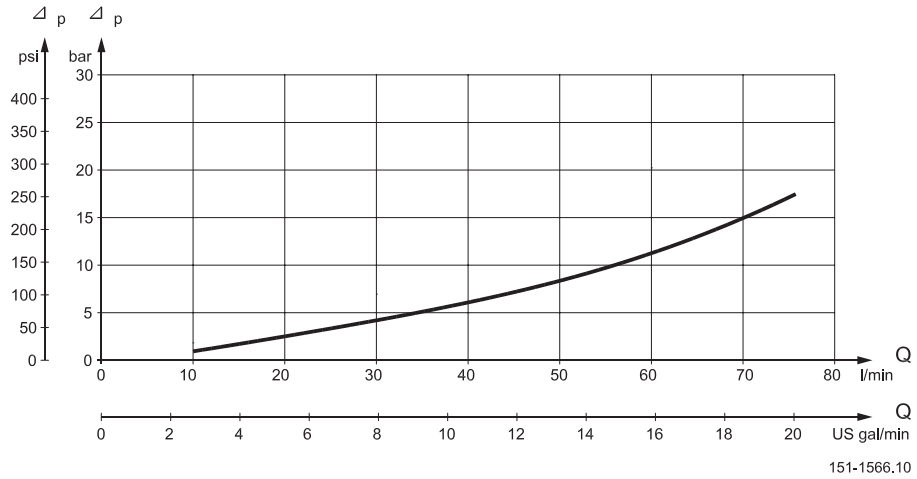

151-1566.10

The curve applies to an unloaded motor shaft and an oil viscosity of 35 mm²/s (165 SUS)

OIL FLOW IN DRAIN LINE

The table shows the max. oil flow in the drain line at a return pressure less than 5-10 bar (75-150 psi).

Pressure drop bar (psi)	Viscosity mm ² /s (SUS)	Oil flow in drain line l/min (US gal/min)
100 (1450)	20 (100)	2.5 (0.66)
	35 (165)	1.8 (0.78)
140 (2030)	20 (100)	3.5 (0.93)
	35 (165)	2.8 (0.74)

DIRECTION OF SHAFT ROTATION

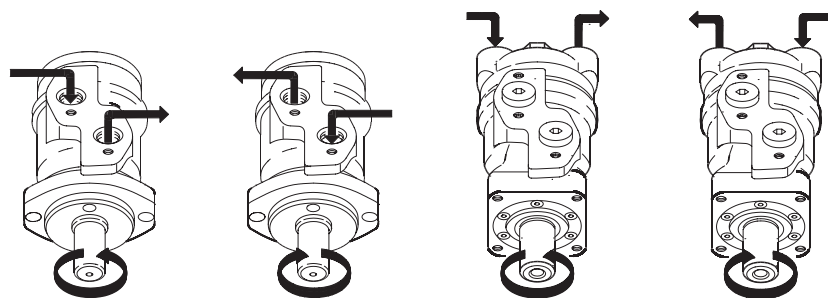

151-1836.10

**PERMISSIBLE SHAFT
LOAD FOR OMR**

The permissible radial shaft load (P_R) depends on

- speed (n)
- distance (l) from the point of load to the mounting flange
- mounting flange version
- shaft version

Mounting flange	4-hole oval flange** 2-hole oval flange (European version)	4-hole oval flange 2-hole oval flange	Square flange** 2-hole oval flange (US version)
Shaft version	25 mm cylindrical shaft 1 in cylindrical shaft 1 in splined shaft 28.5 mm tapered shaft	32 mm cylindrical shaft 1 1/4 in cylindrical shaft	25 mm cylindrical shaft 1 in cylindrical shaft
Permissible shaft load (P_R) l in mm	$\frac{800}{n} \times \frac{250000}{95+l} \text{ N}^*$	$\frac{800}{n} \times \frac{187500}{95+l} \text{ N}^*$	$\frac{800}{n} \times \frac{250000}{101+l} \text{ N}^*$
Permissible shaft load (P_R) l in inch	$\frac{800}{n} \times \frac{2215}{3.74+l} \text{ lbf}^*$	$\frac{800}{n} \times \frac{1660}{3.74+l} \text{ lbf}^*$	$\frac{800}{n} \times \frac{2215}{3.98+l} \text{ lbf}^*$

* $n \geq 200 \text{ min}^{-1} \text{ (rpm)}$; $l \leq 55 \text{ mm (2.2 in)}$
 $n < 200 \text{ min}^{-1} \text{ (rpm)}$; $\Rightarrow P_{Rmax} = 8000 \text{ N (1800 lbf)}$
 ** For both European and US version

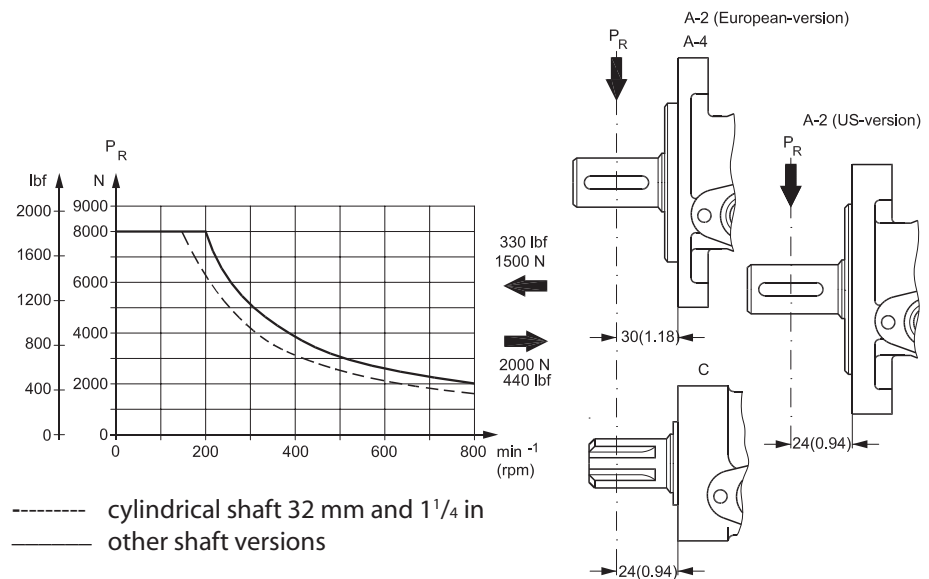

151-1203 10

The curve shows the relation between P_R and n

- when $l = 30 \text{ mm (1.18 in)}$ for motors with oval mounting flange
- when $l = 24 \text{ mm (0.94 in)}$ for motors with square mounting flange

For applications with special performance requirements we recommend OMR with the output shaft running in needle bearings.

**PERMISSIBLE SHAFT
LOAD FOR OMRW N
WITH NEEDLE BEARINGS**

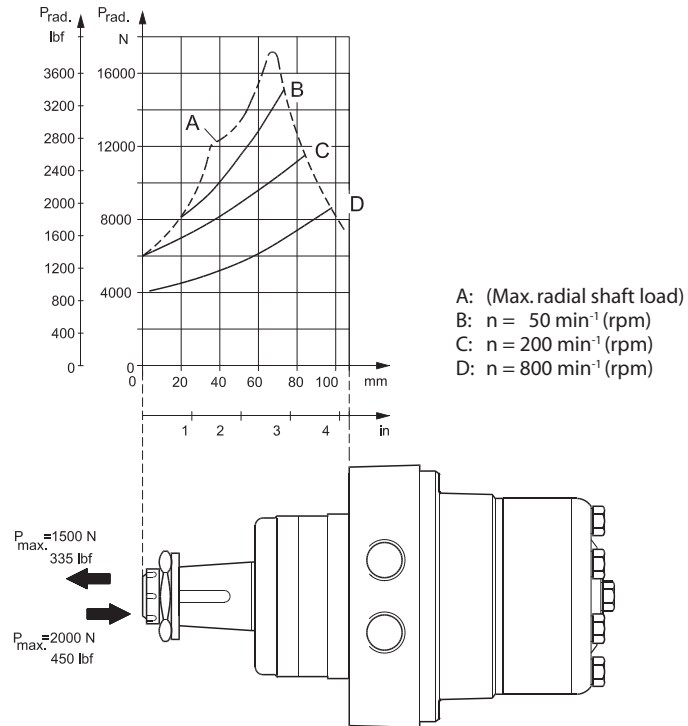

151-1388.10

The output shaft on OMRW N runs in needle bearings. These bearings and the recessed mounting flange allow a higher permissible radial load in comparison to OMR motors with slide bearings.

The permissible radial load on the shaft is shown for different speeds as a function of the distance from the mounting flange to the point of load application.

Curve A shows max. radial shaft load. Any shaft load exceeding the values quoted in the curve will involve a risk of breakage.

The other curves apply to a B10 bearing life of 2000 hours at the number of revolutions indicated by the curve letter. Mineral based hydraulic oil with a sufficient content of anti-wear additives must be used.

Bearing life calculations can be made using the explanation and formula provided in the chapter »Bearing dimensioning« in the technical information "General" DHMH.PK.100.G2.02 520L0232.

FUNCTION DIAGRAMS

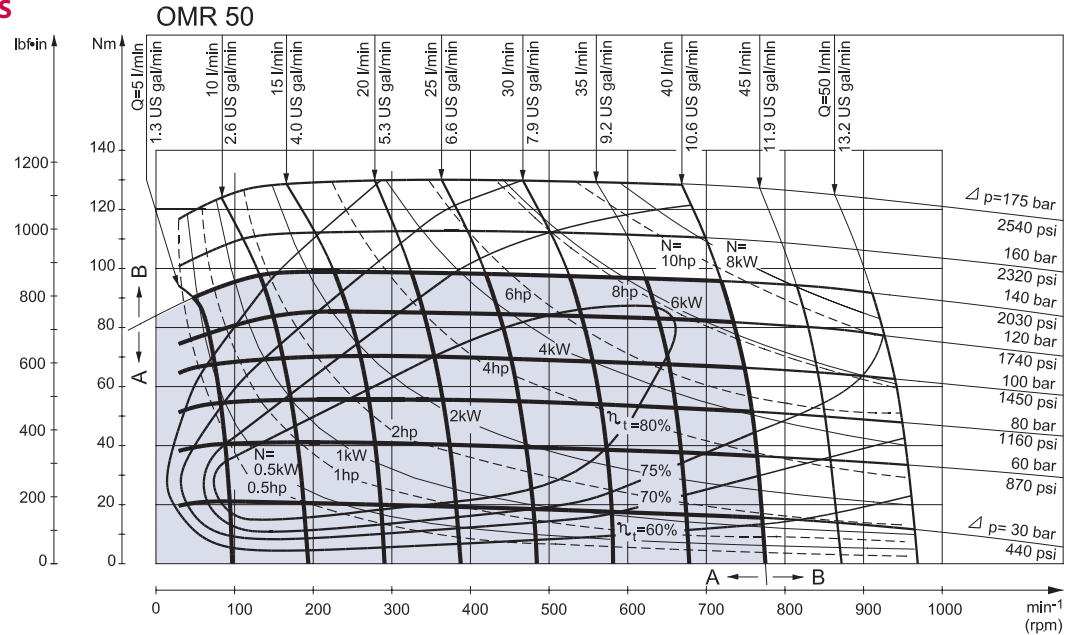

151-1172.10

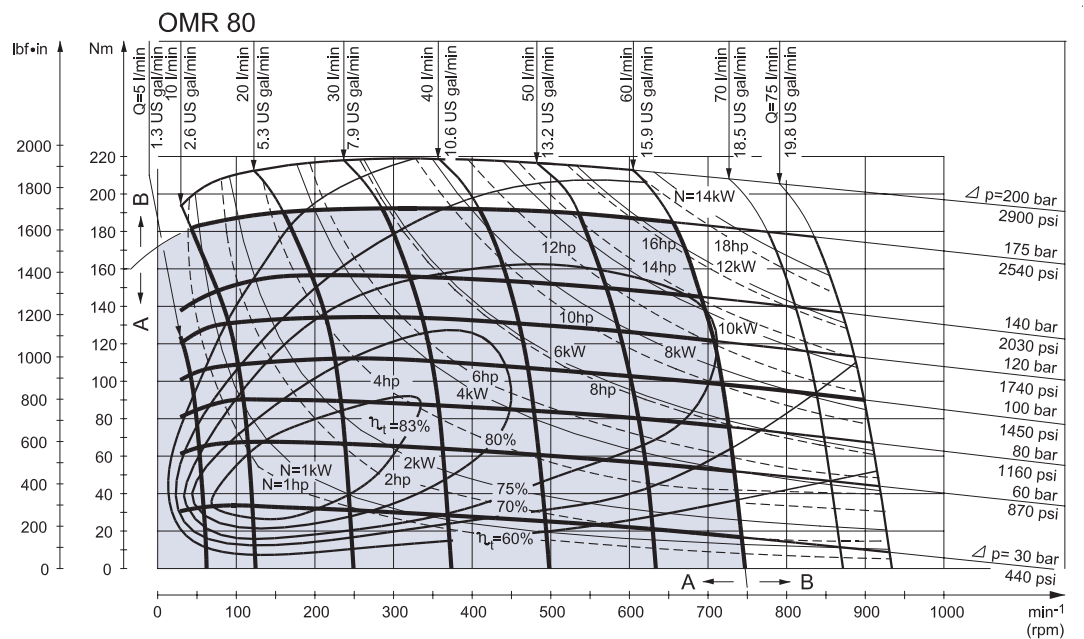

151-299.10

Explanation of function diagram use, basis and conditions can be found on page 7.

- A: Continuous range
- B: Intermittent range (max. 10% operation every minute)

Max. permissible continuous/intermittent pressure drop for the actual shaft version can be found on page 38-40.

Note: Intermittent pressure drop and oil flow must not occur simultaneously.

FUNCTION DIAGRAMS

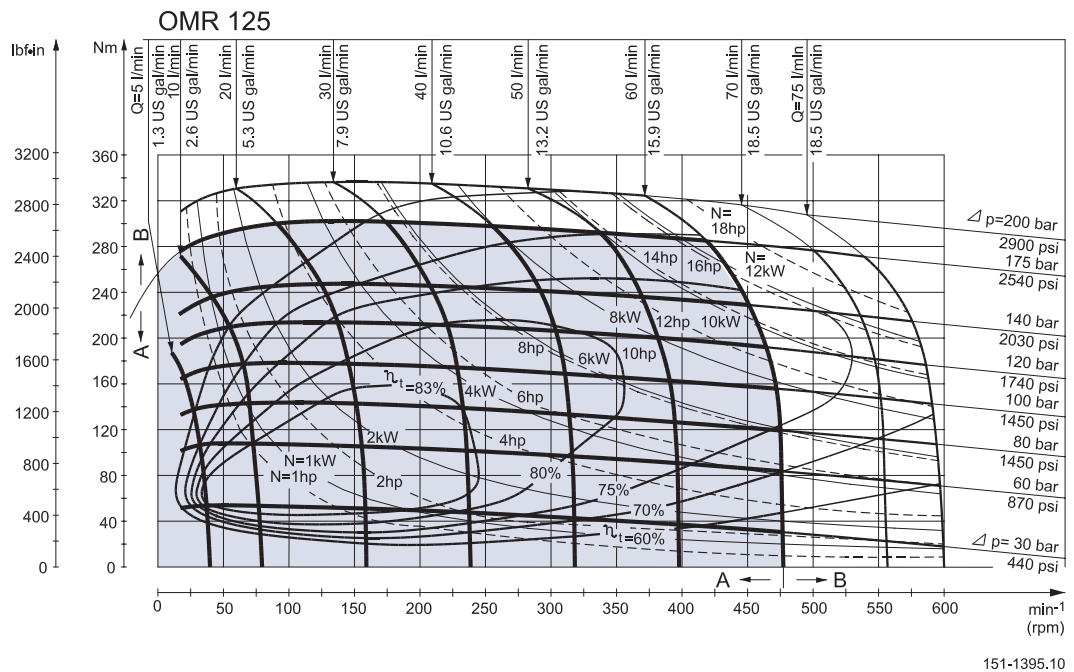
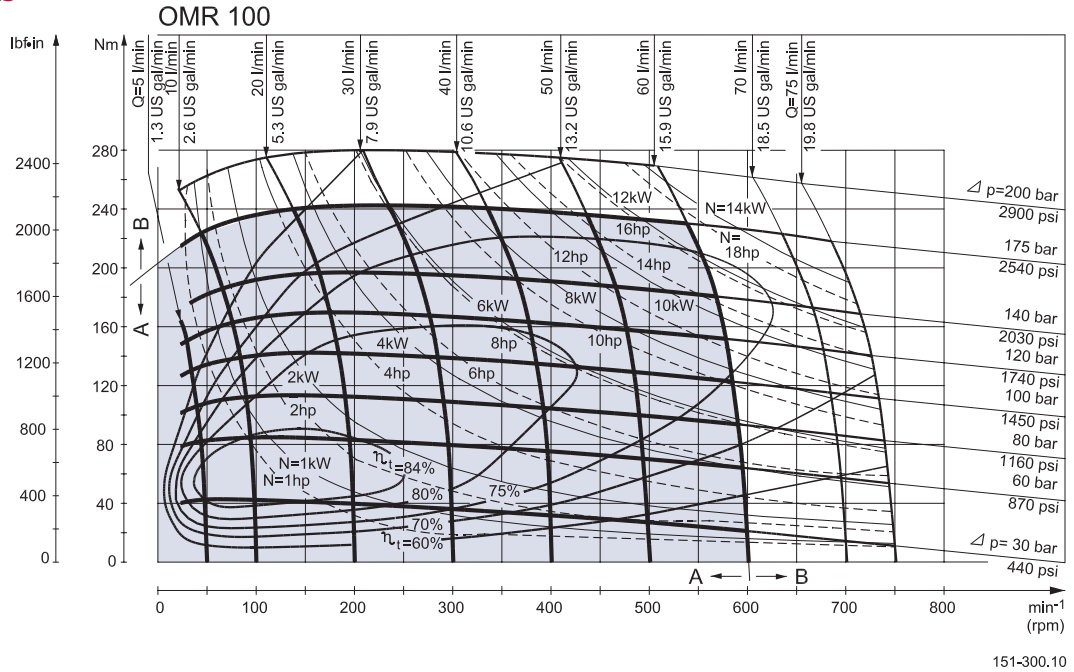

Explanation of function diagram use, basis and conditions can be found on page 7.

- A: Continuous range
- B: Intermittent range (max. 10% operation every minute)

Max. permissible continuous/intermittent pressure drop for the actual shaft version can be found on page 38-40.

Note: Intermittent pressure drop and oil flow must not occur simultaneously.

FUNCTION DIAGRAMS

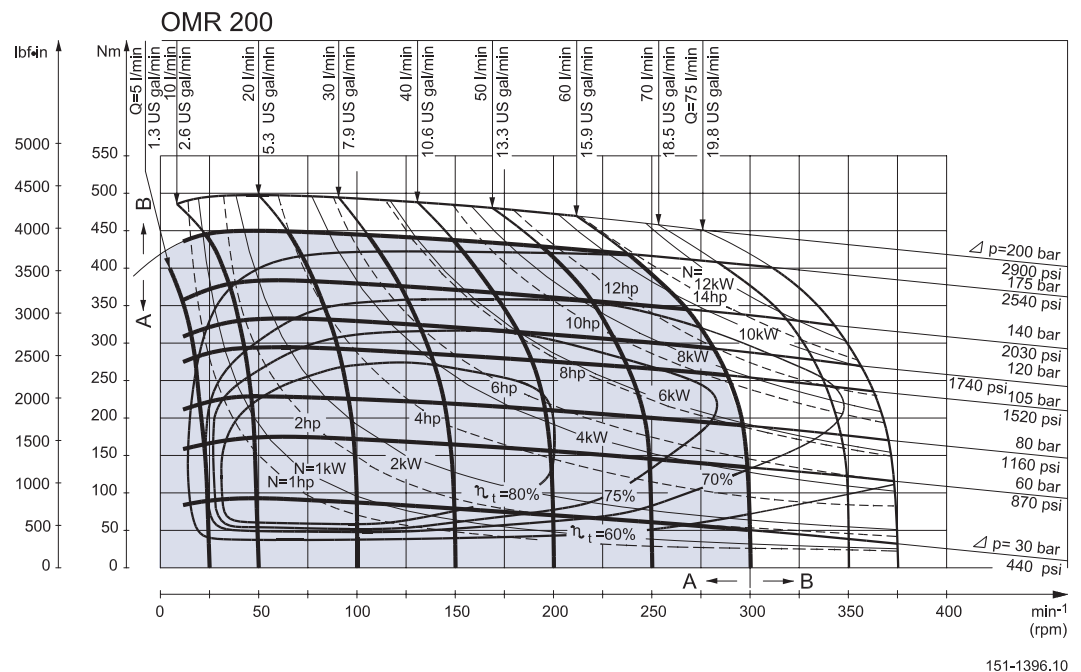
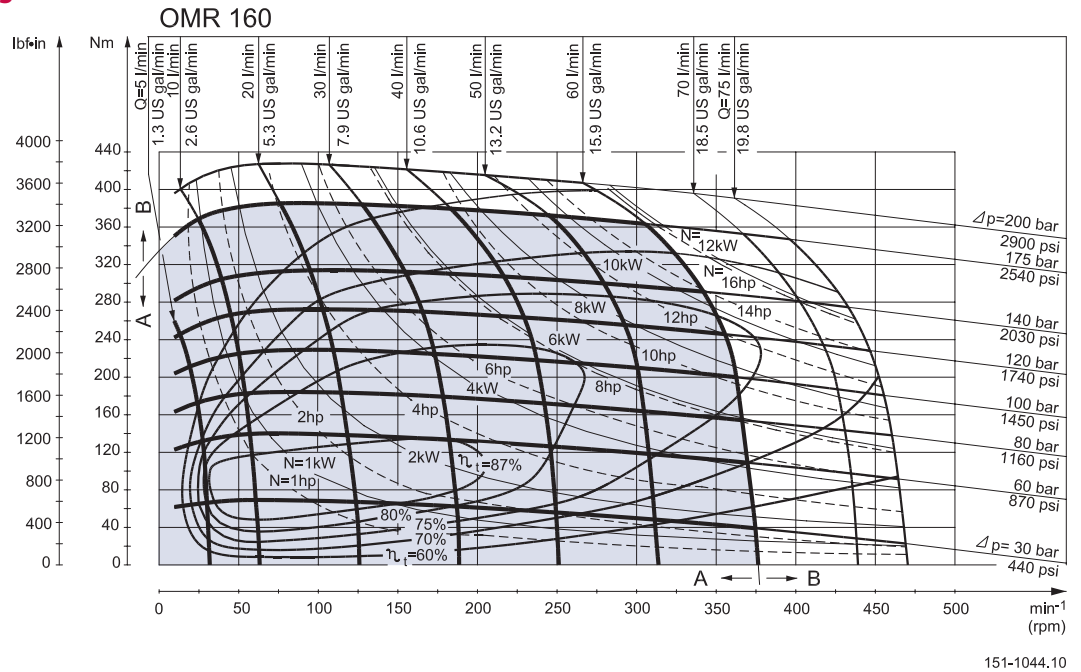

Explanation of function diagram use, basis and conditions can be found on page 7.

- A: Continuous range
- B: Intermittent range (max. 10% operation every minute)

Max. permissible continuous/intermittent pressure drop for the actual shaft version can be found on page 38-40.

Note: Intermittent pressure drop and oil flow must not occur simultaneously.

FUNCTION DIAGRAMS

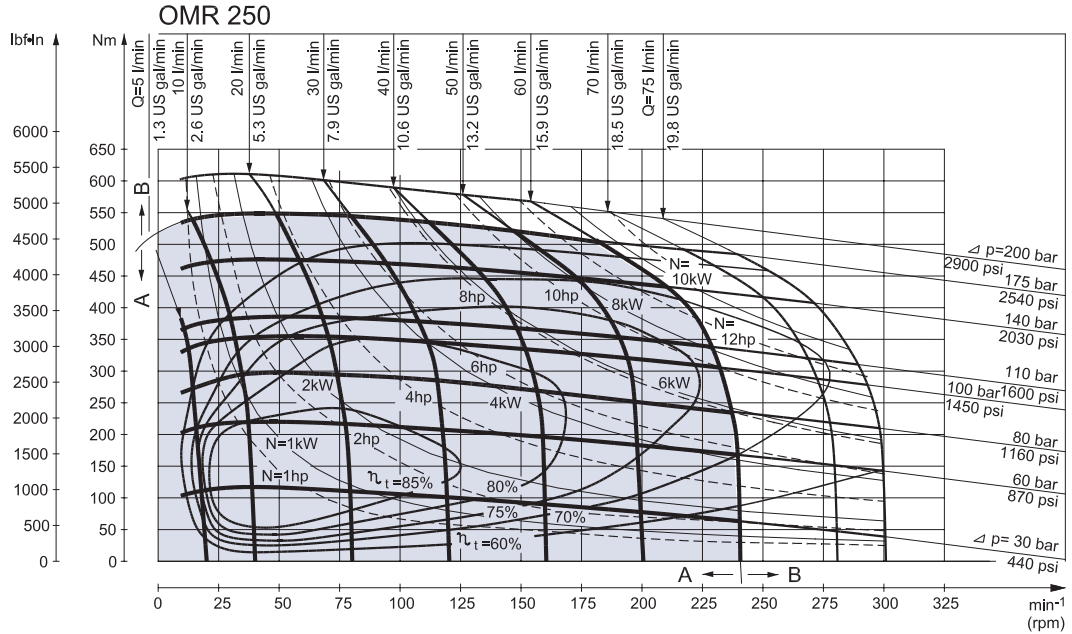

151-1119.10

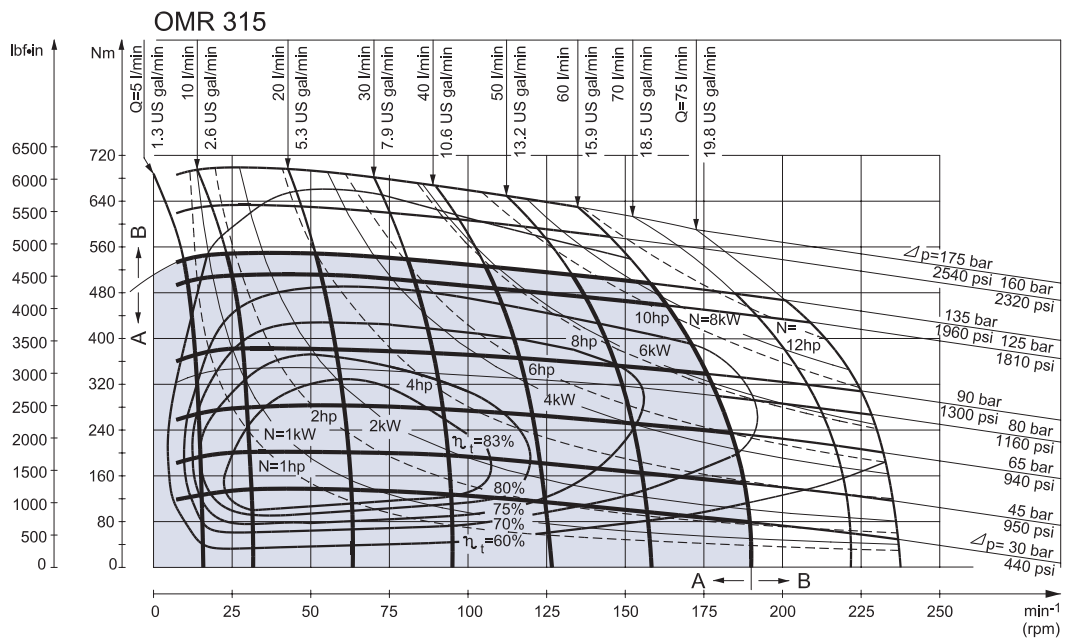

151-809.10

Explanation of function diagram use, basis and conditions can be found on page 7.

- A: Continuous range
- B: Intermittent range (max. 10% operation every minute)

Max. permissible continuous/intermittent pressure drop for the actual shaft version can be found on page 38-40.

Note: Intermittent pressure drop and oil flow must not occur simultaneously.

FUNCTION DIAGRAMS

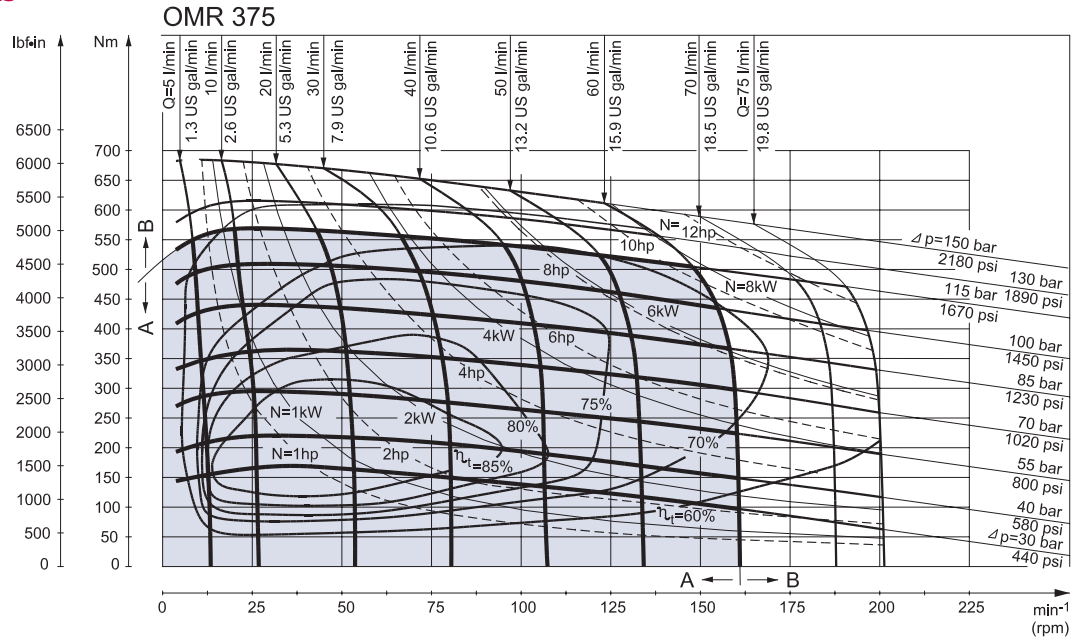

151-1385.10

Explanation of function diagram use, basis and conditions can be found on page 7.

- A: Continuous range
- B: Intermittent range (max. 10% operation every minute)

Max. permissible continuous/intermittent pressure drop for the actual shaft version can be found on page 38-40.

Note: Intermittent pressure drop and oil flow must not occur simultaneously.

SHAFT VERSION

A: Cylindrical shaft
25 mm
D: Parallel key
A8 × 7 × 32
DIN 6885

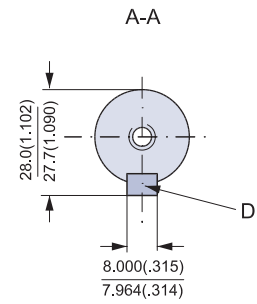
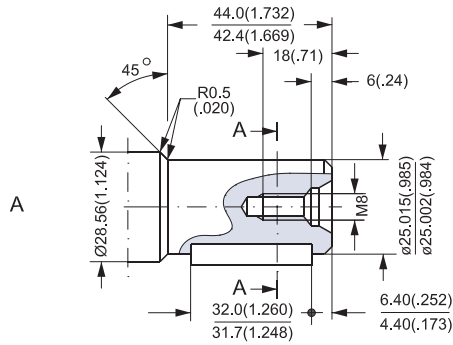

B: Cylindrical shaft
1 in
E: Parallel key
1/4 × 1/4 × 1 1/4 in
B.S. 46

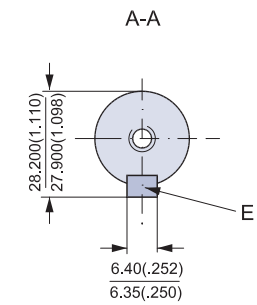
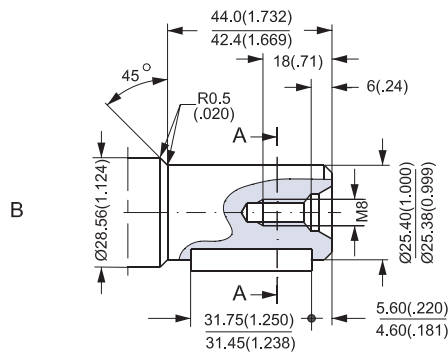

US version
C: Cylindrical shaft
1 in
F: Parallel key
1/4 × 1/4 × 1 1/4 in
B.S. 46

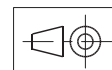
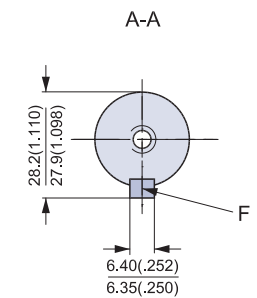
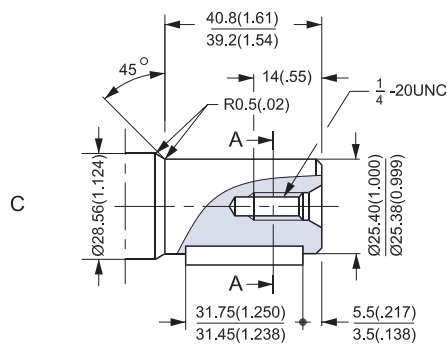

151-1846.10

SHAFT VERSION

D: Cylindrical shaft
32 mm
G: Parallel key
A10 × 8 × 45
DIN 6885

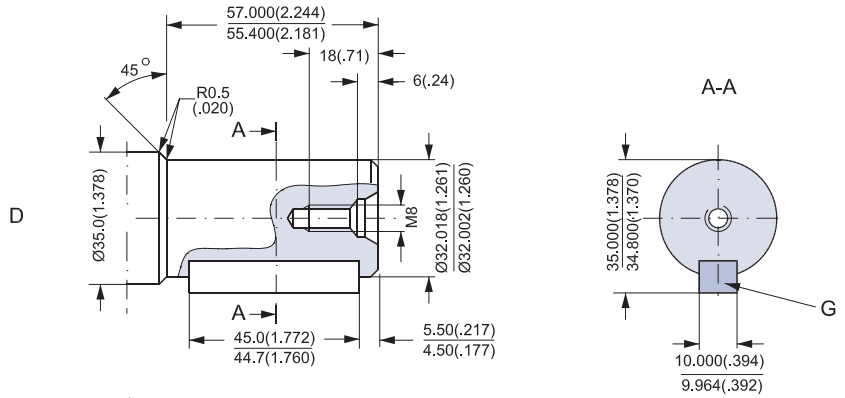

US version

E: Cylindrical shaft
1 1/4 in
H: Parallel key
5/16 × 5/16 × 1 1/4 in
B.S. 46

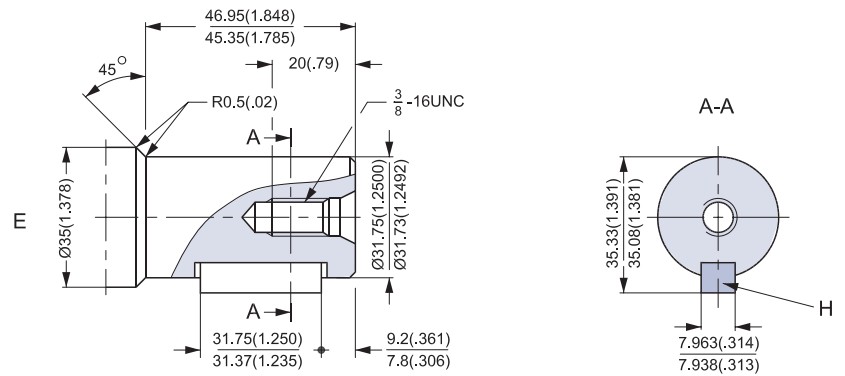

F: Involute splined shaft
B.S. 2059 (SAE 6 B)

Straight-sided,
bottom fitting, deep.
Fit 2
Nom. size 1 in

*Deviates from
B.S. 2059 (SAE 6 B)

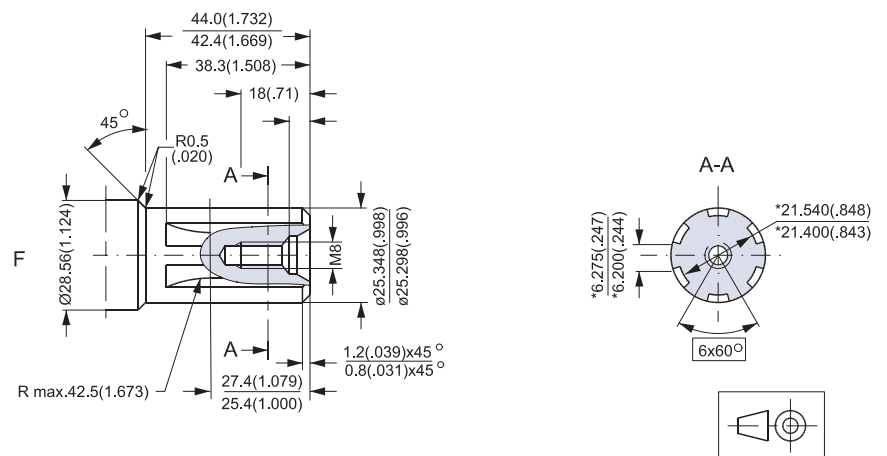

SHAFT VERSION

US version

- G: Splined shaft
- SAE 6 B (B.S. 2059)
- Straight-sided,
- bottom fitting, deep.
- Fit 2
- Nom. size 1 in
- * Deviates from SAE 6 B (B.S. 2059)

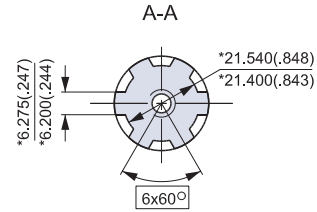
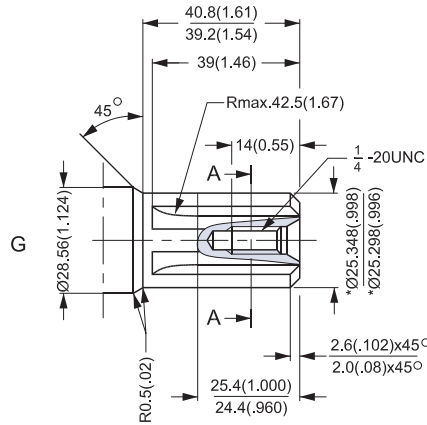

- H: Tapered shaft 28.5 mm (ISO/R775)
- K: DIN 937 NV 30
- Tightening torque: 100 ± 10 Nm (885 ± 85 lbf-in)
- J: Taper 1:10
- L: Parallel key B5 × 5 × 14 DIN 6885

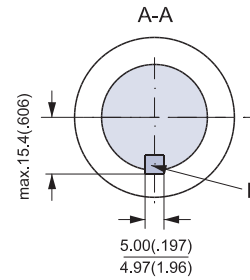
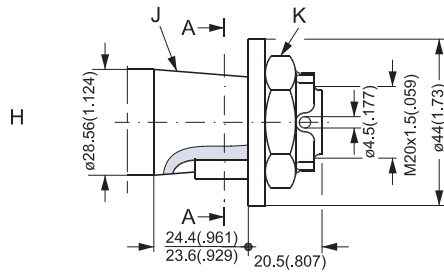

- I: Tapered shaft 35 mm (ISO/R775)
- N: DIN 937 NV 41
- Tightening torque: 200 ± 10 Nm (1770 ± 85 lbf-in)
- M: Taper 1:10
- P: Parallel key B6 × 6 × 20 DIN 6885

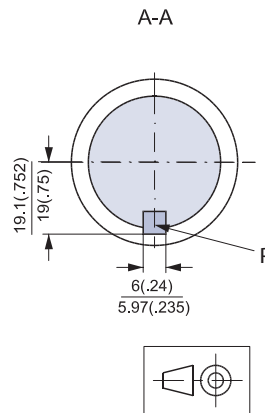
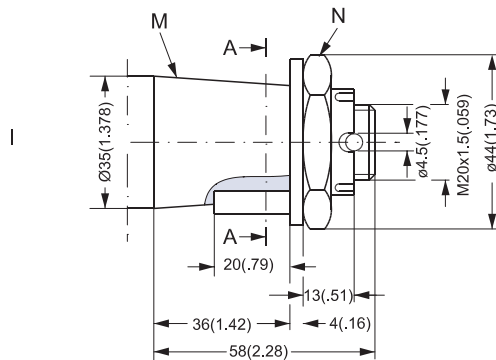

151-1847.10

SHAFT VERSION

- J: Tapered shaft 1 1/4 in
- K: Cone 1:8
SAE J501
- L: 1 - 20 UNEF
Across flats 1 7/16
Tightening torque:
200 ± 10 Nm (1770 ± 85 lbf·in)
- M: Parallel key
5/16 × 5/16 × 1 1/4
SAE J501

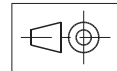
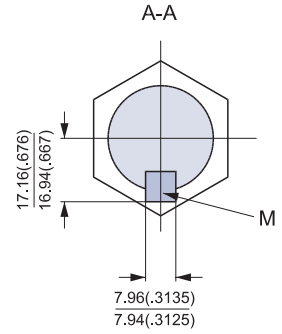
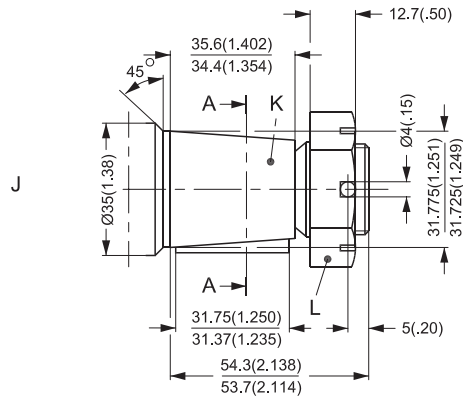

151-1848.10

PORT THREAD VERSIONS

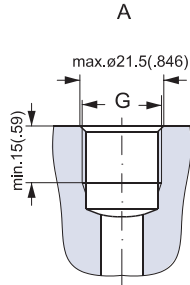

A: G main ports
G: ISO 228/1 - G¹/₂

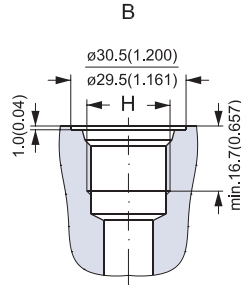

B: UNF main ports
H: ⁷/₈ - 14 UNF
O-ring boss port

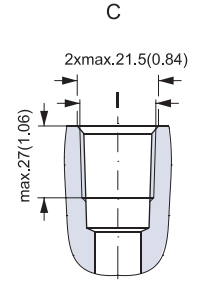

C: NPTF main ports
I: ¹/₂ - 14 NPTF

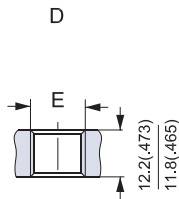

D: G drain port
E: ISO 228/1 - G¹/₄

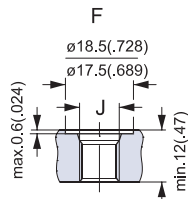

F: UNF drain port
J: ⁷/₁₆ - 20 UNF
O-ring boss port

151-1844.10

DIMENSIONS

Side port version with 2-hole oval mounting flange (A2 flange).
With high pressure shaft seal.

Type	L mm (in)	L ₁ mm (in)
OMR 50	135.5 (5.33)	9.0 (0.35)
OMR 80	140.5 (5.53)	14.0 (0.55)
OMR 100	144.0 (5.67)	17.4 (0.69)
OMR 125	148.5 (5.85)	21.8 (0.86)
OMR 160	154.5 (6.08)	27.8 (1.09)
OMR 200	161.5 (6.36)	34.8 (1.37)
OMR 250	170.5 (6.71)	43.5 (1.71)
OMR 315	181.5 (7.15)	54.8 (2.16)
OMR 375	191.7 (7.55)	65.0 (2.56)

D: G 1/2; 15 mm (0.59 in) deep
E: M8; 13 mm (0.51 in) deep
(4 pcs.)

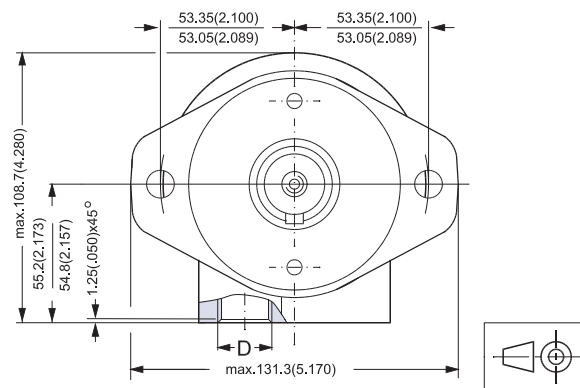
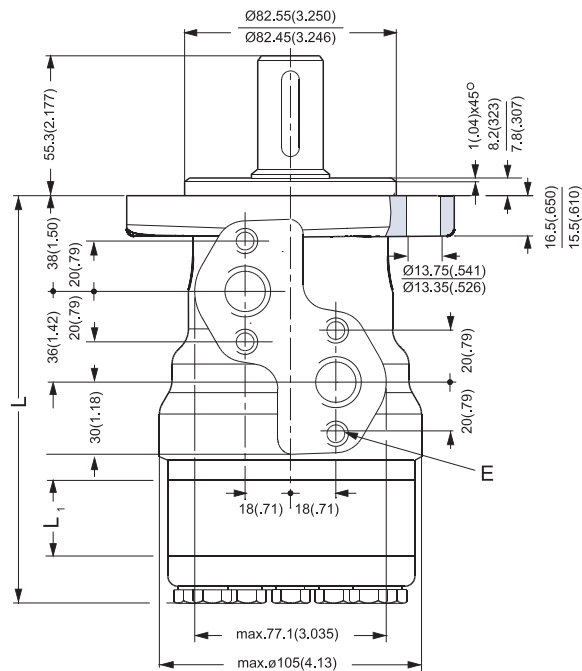

151-1750.10

DIMENSIONS

Side port version with 2-hole oval mounting flange (A2 flange).
With check valves and drain connection.
With high pressure shaft seal.

Type	L mm (in)	L ₁ mm (in)
OMR 50	135.5 (5.33)	9.0 (0.35)
OMR 80	140.5 (5.53)	14.0 (0.55)
OMR 100	144.0 (5.67)	17.4 (0.69)
OMR 125	148.5 (5.85)	21.8 (0.86)
OMR 160	154.5 (6.08)	27.8 (1.09)
OMR 200	161.5 (6.36)	34.8 (1.37)
OMR 250	170.5 (6.71)	43.5 (1.71)
OMR 315	181.5 (7.15)	54.8 (2.16)
OMR 375	191.7 (7.55)	65.0 (2.56)

- C: Drain connection
G 1/4; 12 mm (0.47 in) deep
- D: G 1/2; 15 mm (0.59 in) deep
- E: M8; 13 mm (0.51 in) deep
(4 pcs.)

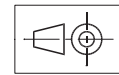
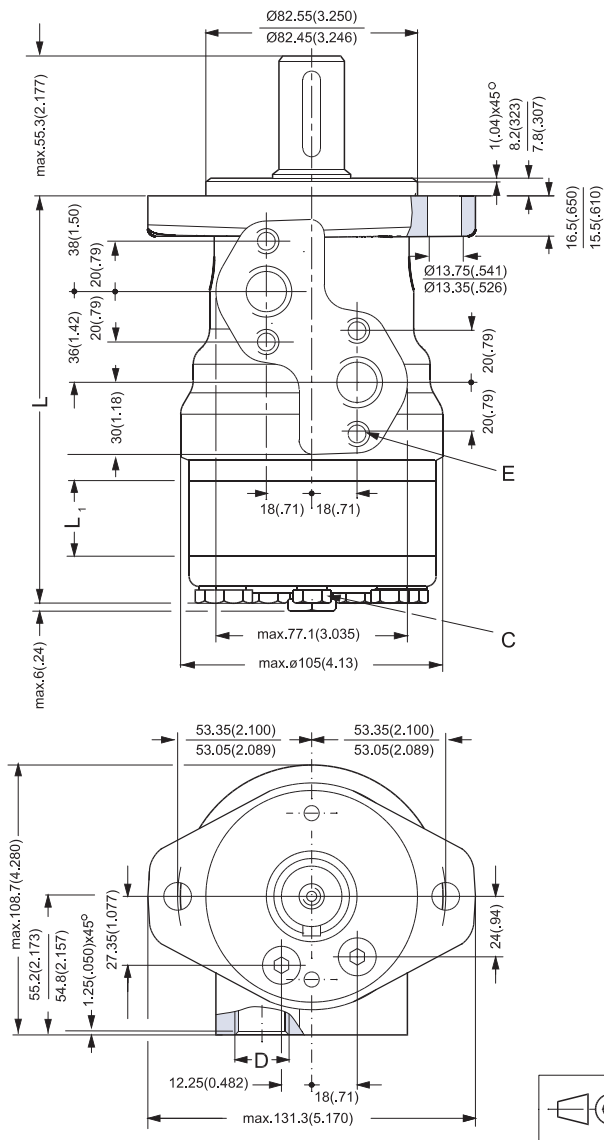

151-1845.10

DIMENSIONS

Side port version with 2-hole oval mounting flange (A2 flange).

Output shaft. max.	mm L ₂ (in)
Cylindrical shaft 32 mm (1.26 in)	68.3 (2.69)
Cylindrical shaft 25 mm	55.3 (2.16)
Tapered shaft 28.56 mm (1.12 in)	56.3 (2.19)

Type	L mm (in)	L ₁ mm (in)
OMR 50	135.5 (5.33)	9.0 (0.35)
OMR 80	140.5 (5.53)	14.0 (0.55)
OMR 100	144.0 (5.67)	17.4 (0.69)
OMR 125	148.5 (5.85)	21.8 (0.86)
OMR 160	154.5 (6.08)	27.8 (1.09)
OMR 200	161.5 (6.36)	34.8 (1.37)
OMR 250	170.5 (6.71)	43.5 (1.71)
OMR 315	181.5 (7.15)	54.8 (2.16)
OMR 375	191.7 (7.55)	65.0 (2.56)

- C: Drain connection
G 1/4; 12 mm (0.47 in) deep
- D: G 1/2; 15 mm (0.59 in) deep
- E: M8; 13 mm (0.51 in) deep
(4 pcs.)

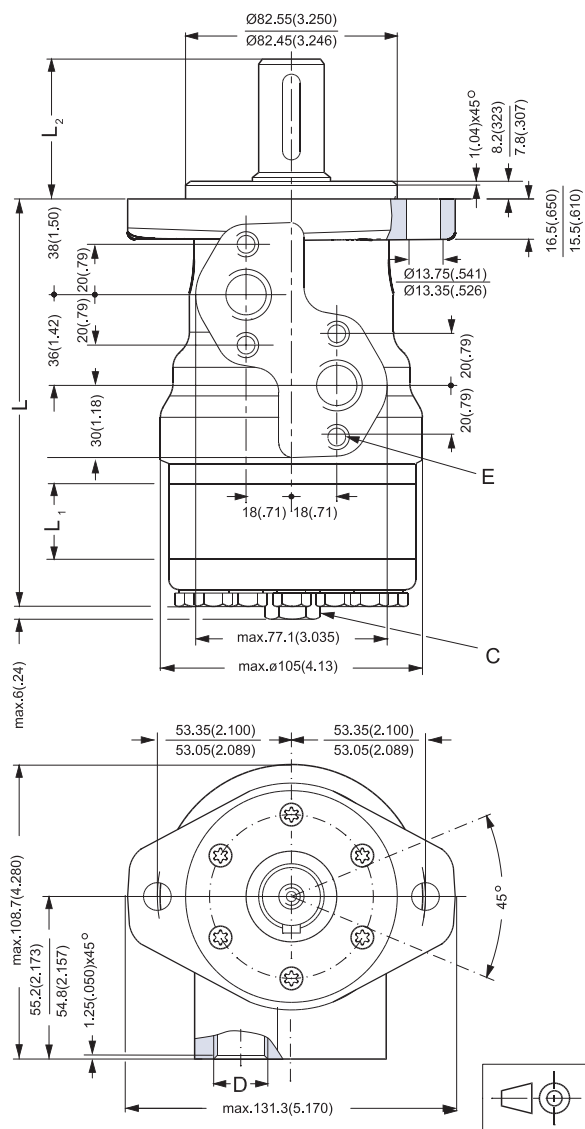

151-1849.10

DIMENSIONS

End port version with 2-hole oval mounting flange (A2-flange).

Type	L mm (in)	L ₁ mm (in)
OMR 50	150.6 (5.92)	9.0 (0.35)
OMR 80	155.6 (6.13)	14.0 (0.55)
OMR 100	159.0 (6.26)	17.4 (0.69)
OMR 125	163.4 (6.43)	21.8 (0.86)
OMR 160	169.4 (6.67)	27.8 (1.09)
OMR 200	176.4 (6.94)	34.8 (1.37)
OMR 250	185.1 (7.29)	43.5 (1.71)
OMR 315	196.4 (7.73)	54.8 (2.16)
OMR 400	206.6 (8.13)	65.0 (2.56)

C: Drain connection
G 1/4; 12 mm (0.47 in) deep
D: G 1/2; 15 mm (0.59 in) deep

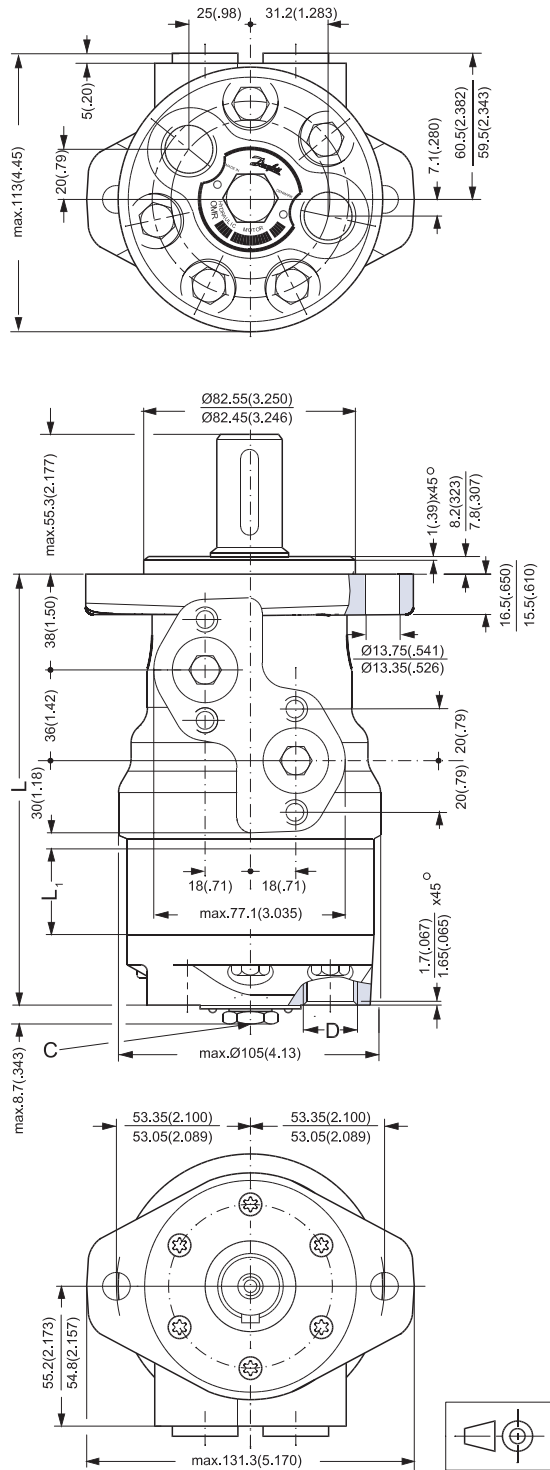

151-1752.10

DIMENSIONS

Side port version with 2-hole oval mounting flange (A2-flange).

Type	L mm (in)	L ₁ mm (in)
OMR 50	141.5 (5.57)	9.0 (0.35)
OMR 80	146.5 (5.77)	14.0 (0.55)
OMR 100	150.0 (5.91)	17.4 (0.69)
OMR 125	154.4 (6.08)	21.8 (0.86)
OMR 160	160.5 (6.32)	27.8 (1.09)
OMR 200	167.5 (6.59)	34.8 (1.37)
OMR 250	176.5 (6.95)	43.5 (1.71)
OMR 315	187.5 (7.38)	54.8 (2.16)
OMR 400	197.5 (7.78)	64.8 (2.55)

- C: Drain connection
7/16 - 20 UNF;
12 mm (0.47 in) deep
- D: 7/8 - 14 UNF;
16.76 mm (0.66 in) deep
- E: M8; 13 mm (0.51 in) deep
(4-off)

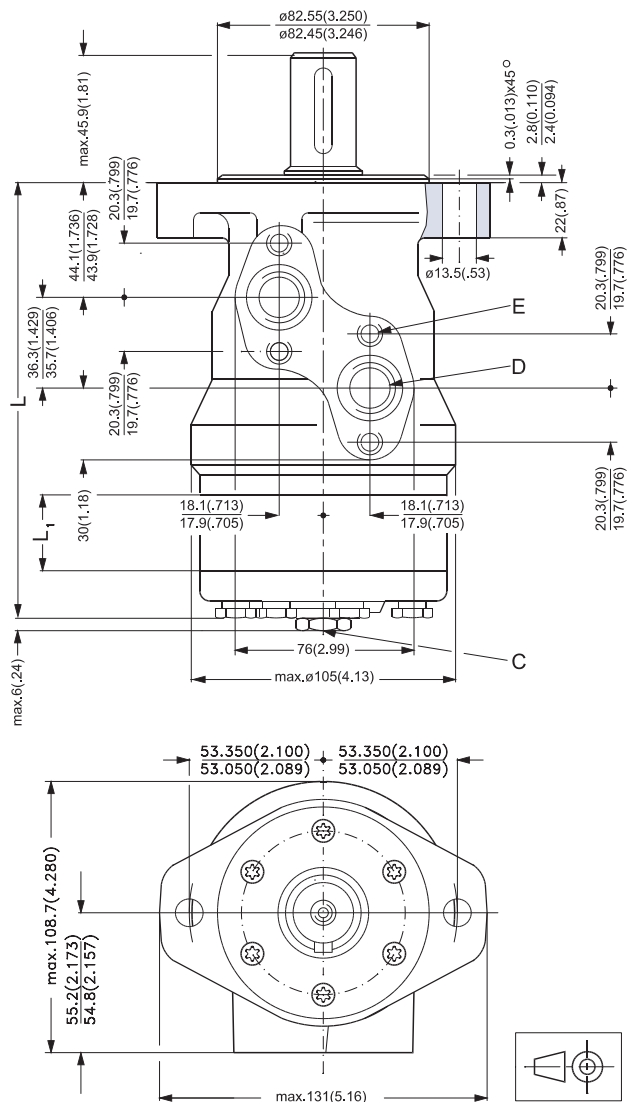

151-1223.10

DIMENSIONS

Side port version with 4-hole oval mounting flange (A4 flange).

Output shaft. max.	mm L ₂ (in)
Cylindrical shaft 32 mm (1.26 in)	68.3 (2.69)
Cylindrical shaft 25 mm (0.98 in)	55.3 (2.16)

Type	L mm (in)	L ₁ mm (in)
OMR 50	135.5 (5.33)	9.0 (0.35)
OMR 80	140.5 (5.53)	14.0 (0.55)
OMR 100	144.0 (5.67)	17.4 (0.69)
OMR 125	148.5 (5.85)	21.8 (0.86)
OMR 160	154.5 (6.08)	27.8 (1.09)
OMR 200	161.5 (6.36)	34.8 (1.37)
OMR 250	170.5 (6.71)	43.5 (1.71)
OMR 315	181.5 (7.15)	54.8 (2.16)
OMR 375	191.7 (7.55)	65.0 (2.56)

- C: Drain connection
G 1/4; 12 mm (0.47 in) deep
- D: G 1/2; 15 mm (0.59 in) deep
- E: M8; 13 mm (0.51 in) deep
(4 pcs.)

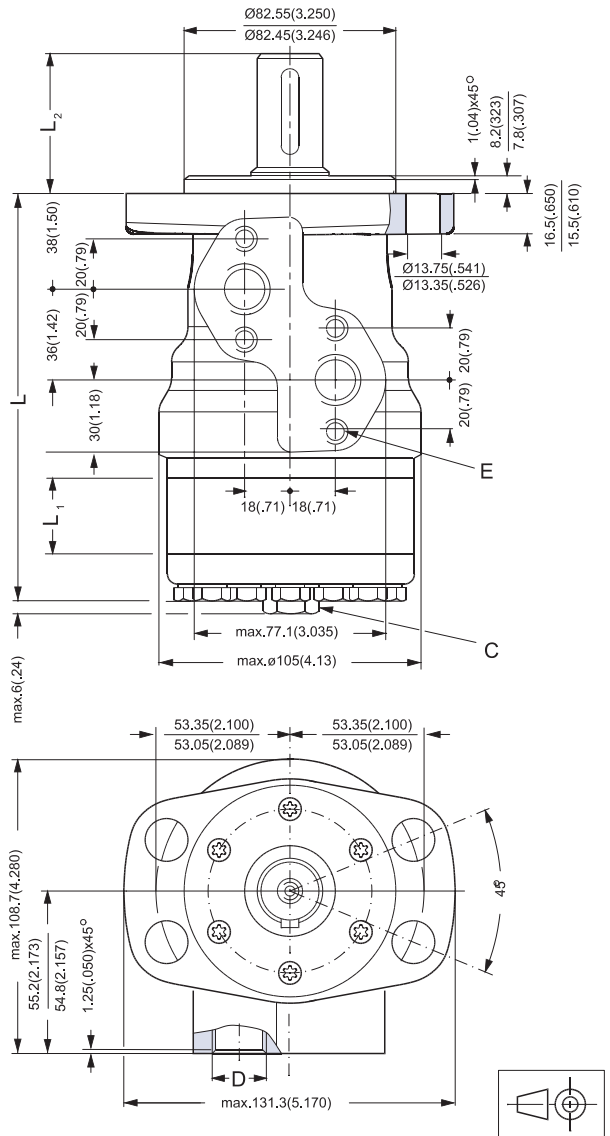

151-1751.10

DIMENSIONS

Side port version with 4-hole oval mounting flange (A4-flange).

Type	L mm (in)	L ₁ mm (in)
OMR 50	135.5 (5.33)	9.0 (0.35)
OMR 80	140.5 (5.53)	14.0 (0.55)
OMR 100	144.0 (5.67)	17.4 (0.69)
OMR 125	148.4 (5.84)	21.8 (0.86)
OMR 160	154.5 (6.08)	27.8 (1.09)
OMR 200	161.5 (6.36)	34.8 (1.37)
OMR 250	170.5 (6.71)	43.5 (1.71)
OMR 315	181.5 (7.15)	54.8 (2.16)
OMR 400	191.5 (7.55)	64.8 (2.55)

- C: Drain connection
7/16 - 20 UNF;
12 mm (0.47 in) deep
- D: 7/8 - 14 UNF;
16.76 mm (0.66 in) deep
- E: M8; 13 mm (0.51 in) deep
(4-off)

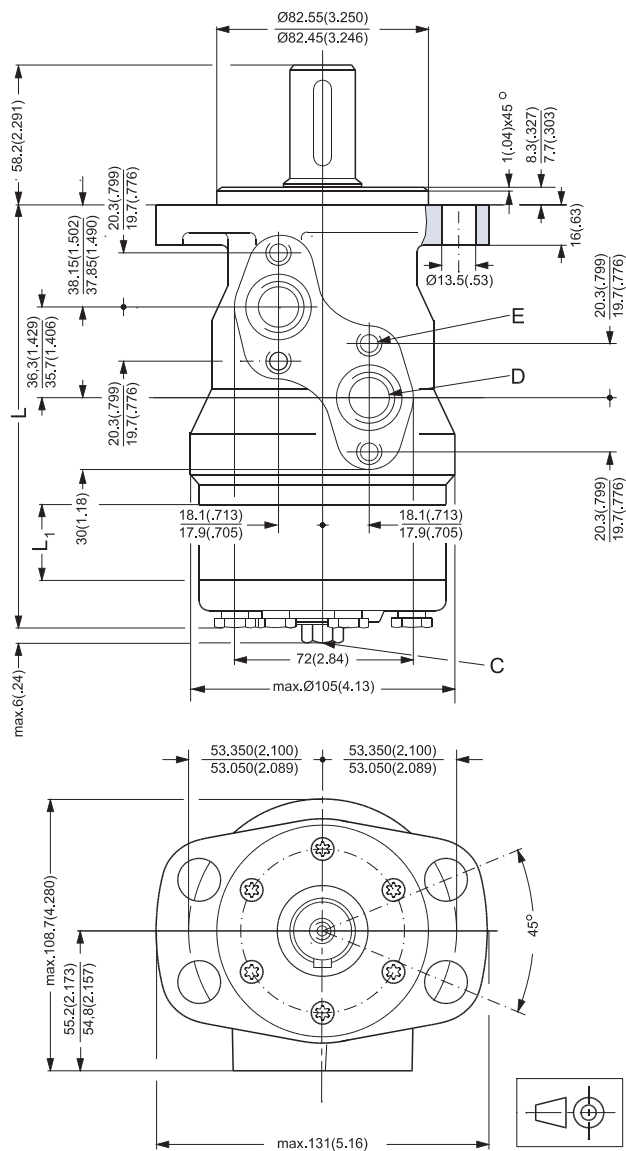

151-1221.10

DIMENSIONS

End port version with square mounting flange (C-flange).

Type	L mm (in)	L ₁ mm (in)
OMR 50	156.6 (6.17)	9.0 (0.35)
OMR 80	161.6 (6.36)	14.0 (0.55)
OMR 100	165.0 (6.50)	17.4 (0.69)
OMR 125	169.4 (6.67)	21.8 (0.86)
OMR 160	175.4 (6.91)	27.8 (1.09)
OMR 200	182.4 (7.18)	34.8 (1.37)
OMR 250	191.1 (7.52)	43.5 (1.71)
OMR 315	202.4 (7.98)	54.8 (2.16)
OMR 375	212.5 (8.37)	65.0 (2.56)

- C: Drain connection
G 1/4; 12 mm (0.47 in) deep
- D: G 1/2; 15 mm (0.59 in) deep
- E: M10; 15 mm (0.59 in) deep
(4 pcs.)

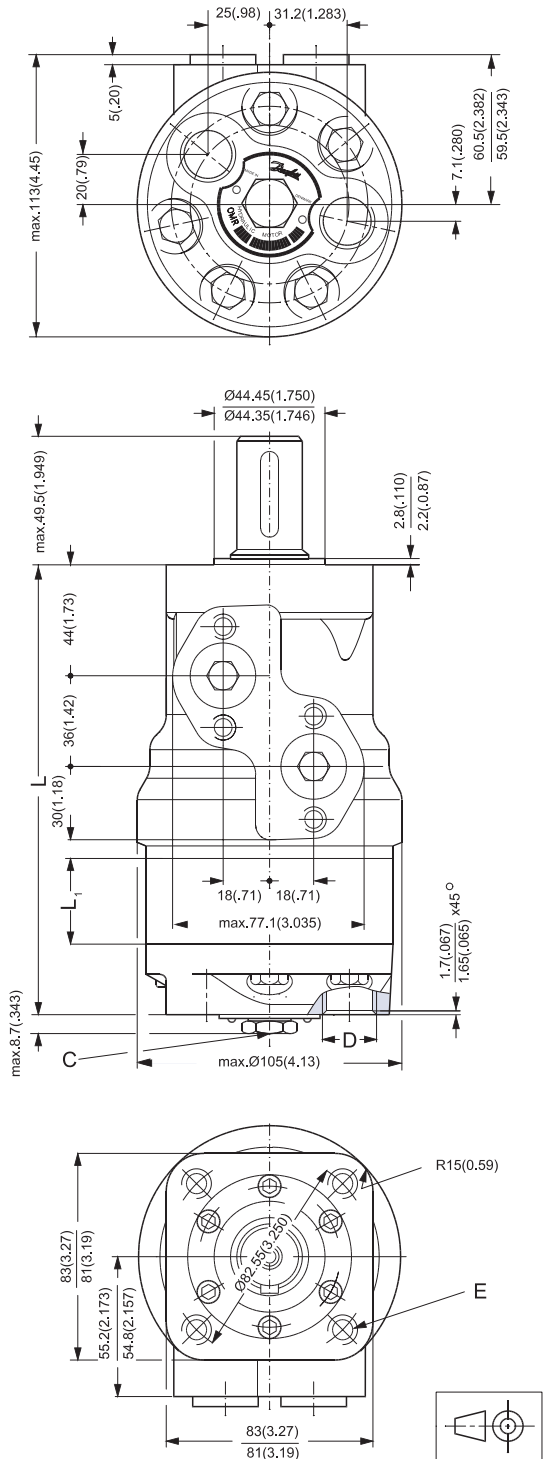

151-1753.10

DIMENSIONS

Side port version with square mounting flange (C-flange).

Type	L mm (in)	L ₁ mm (in)
OMR 50	141.5 (5.57)	9.0 (0.35)
OMR 80	146.5 (5.77)	14.0 (0.55)
OMR 100	150.0 (5.91)	17.4 (0.69)
OMR 125	154.4 (6.08)	21.8 (0.86)
OMR 160	160.5 (6.32)	27.8 (1.09)
OMR 200	167.5 (6.59)	34.8 (1.37)
OMR 250	176.5 (6.95)	43.5 (1.71)
OMR 315	187.5 (7.38)	54.8 (2.16)
OMR 375	197.7 (7.78)	64.8 (2.55)

- C: Drain connection
7/16 - 20 UNF;
12 mm (0.47 in) deep
- D: 7/8 - 14 UNF;
17 mm (0.66 in) deep
- E: M8; 13 mm (0.51 in) deep
(4-off)
- F: 3/8 - 16 UNC;
15 mm (0.59 in) deep
(4-off)

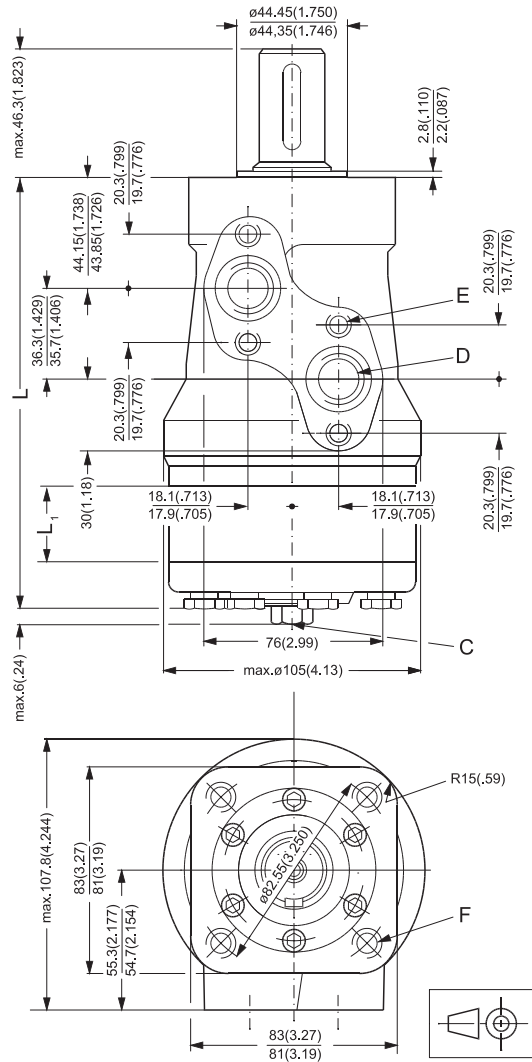

151-1220.10

DIMENSIONS
OMRW N

OMRW N wheel motor.

Type	L mm (in)	L ₁ mm (in)
OMRW 50N	106.0 (4.17)	9.0 (0.35)
OMRW 80N	111.0 (4.37)	14.0 (0.55)
OMRW 100N	114.4 (4.50)	17.4 (0.69)
OMRW 125N	118.8 (4.68)	21.8 (0.86)
OMRW 160N	124.8 (4.91)	27.8 (1.09)
OMRW 200N	131.8 (5.19)	34.8 (1.37)
OMRW 250N	140.5 (5.53)	43.5 (1.71)
OMRW 315N	152.0 (5.98)	54.8 (2.16)
OMRW 375N	162.0 (6.38)	65.0 (2.56)

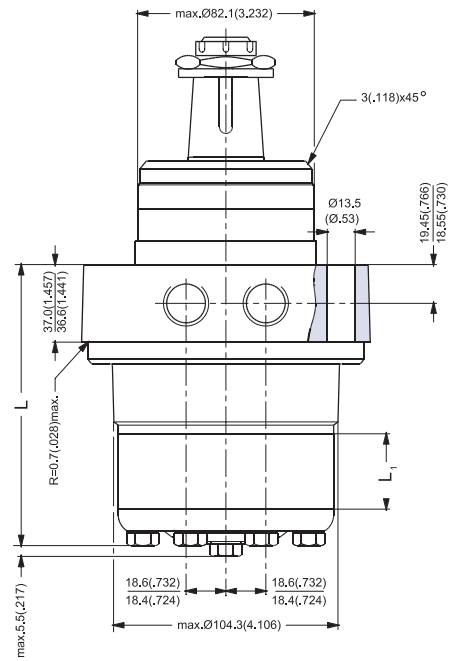
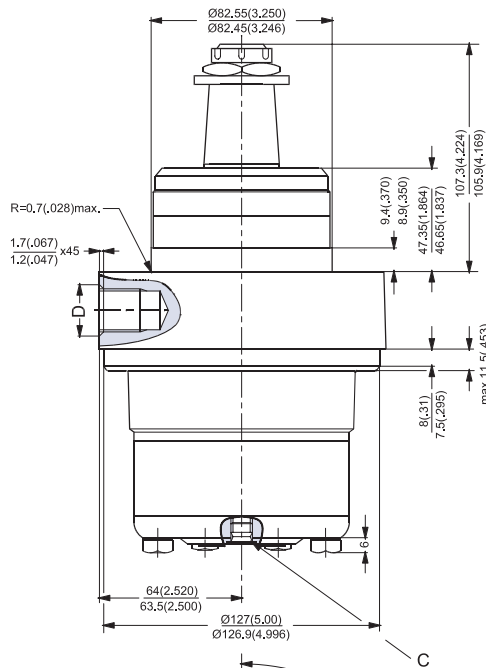

C: Drain connection
G 1/4; 12 mm (0.47 in) deep
D: G 1/2; 15 mm (0.59 in) deep

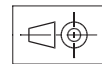
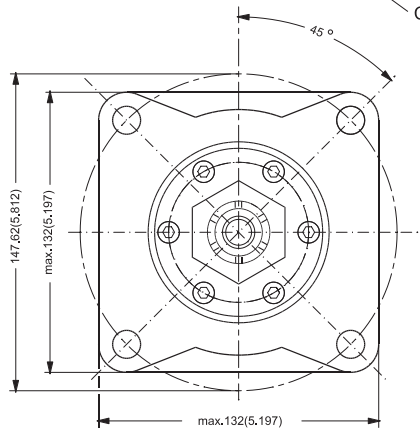

151-1386.10

DIMENSIONS
OMRW N

OMRW N wheel motor.

Type	L mm (in)	L ₁ mm (in)
OMRW 50N	106.0 (4.17)	9.0 (0.35)
OMRW 80N	111.0 (4.37)	14.0 (0.55)
OMRW 100N	114.4 (4.50)	17.4 (0.69)
OMRW 125N	118.8 (4.68)	21.8 (0.86)
OMRW 160N	124.8 (4.91)	27.8 (1.09)
OMRW 200N	131.8 (5.19)	34.8 (1.37)
OMRW 250N	140.5 (5.53)	43.5 (1.71)
OMRW 315N	152.0 (5.98)	54.8 (2.16)
OMRW 375N	162.0 (6.38)	65.0 (2.56)

- C: Drain connection
7/16 - 20 UNF
12 mm (0.47 in) deep
- D: 7/8 - 14 UNF
17 mm (0.66 in) deep

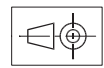
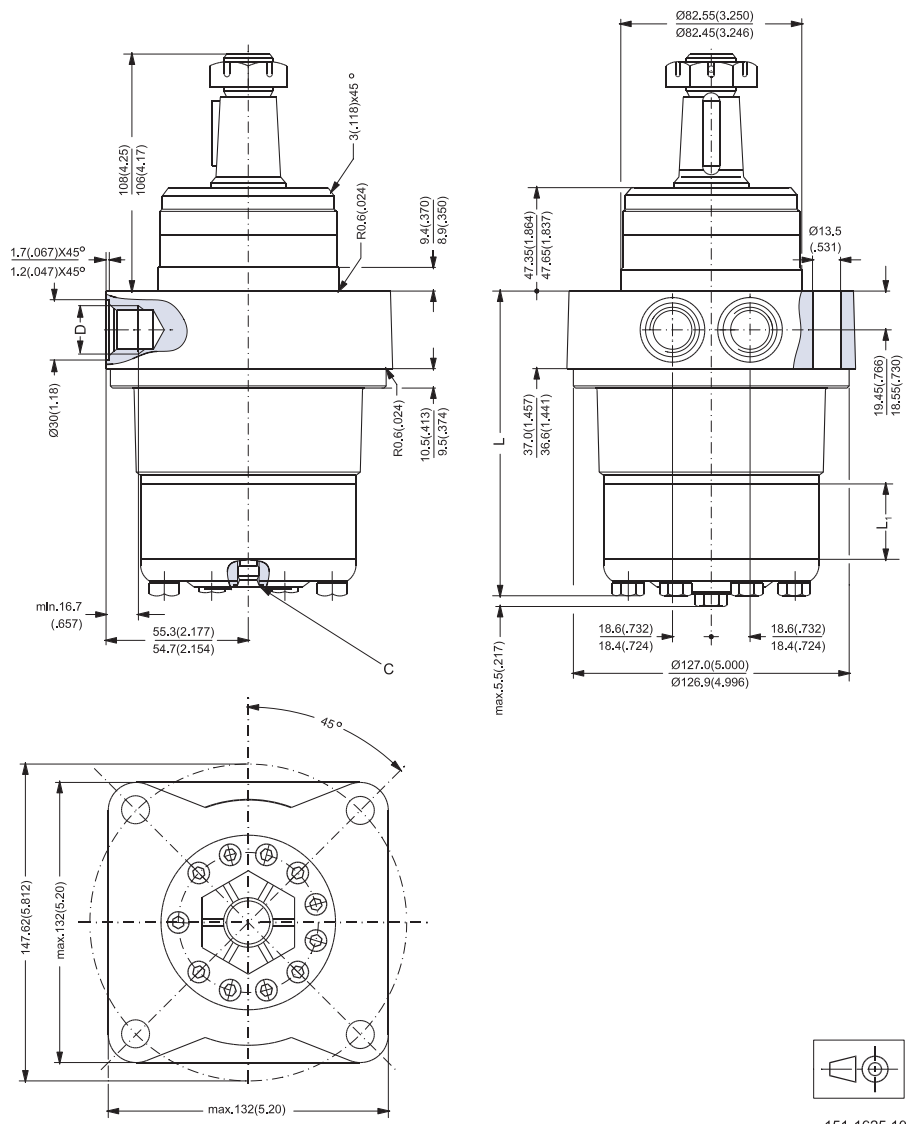

151-1625.10